

Made in Italy  
PRODUCT



DEA<sup>®</sup>



SLIDING



LIVI

Automation for sliding gates

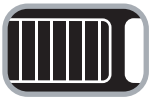

# Electromechanical operator for sliding gates

# LIVI

THE STURDINESS, BORN OF THE LONG EXPERIENCE

**LIVI** is the operator for sliding gates up to 900 kg, which combines a great **sturdiness** and **reliability** with an agreeable and original design, which has been marking out this product for several years.

Thanks to the mechanical or electronic clutch, the **safety** is assured.

The control board is integrated in the case, making so still easier the already quick installation of Livi 400 and its programming is rapid, precise and stable.



RANGE **LIVI**

## Range RR\*

**6RR:** operator 230V ac, for gates up to 600 kg, built-in control board art. 203RR\*.

**9RR:** operator 230V ac, for gates up to 900 kg, built-in control board art. 203RR\*.

**805RR:** operator 230V ac, for gates up to 800 kg, built-in control board art. 203RR\*, not self-locking.

**5/24RR/F:** operator 24V dc, for gates up to 500 kg, built-in control board art. 124RR\*, built in limit switches.

**5/24RRB/F:** operator 24V dc, for gates up to 500 kg, built-in control board art. 124RR\*, 2 integrated batteries 12V 1,2Ah, built in limit switches.

**8/24RR/F:** operator 24V dc, for gates up to 800 kg, built-in control board art. 124RR\*, built in limit switches.

**8/24RRB/F:** operator 24V dc, for gates up to 800 kg, built-in control board art. 124RR\*, 2 integrated batteries 12V 1,2Ah, built in limit switches.

*\*all control boards included in the RR range come equipped with a 2-channel wireless receiver 433 Mhz, pedestrian opening, electronic adjustment of speed and force, reverser function on obstacle and slow-down.*

*All functions are adjusted by 3 buttons and a digital display.*

## Other 230V models:

**400:** operator 230V ac, for gates up to 400 kg, with mechanical clutch.

**403E:** operator 230V ac, for gates up to 400 Kg., built-in control board art. 212E

**800:** operator 230V ac, for gates up to 800 kg, with mechanical clutch.

**803E:** operator 230V ac, for gates up to 800 Kg., built-in control board art. 212E

**804:** operator 230V ac, for gates up to 800 kg, with mechanical clutch, not self-locking.

*DEA System control boards are planned to optimize the performances of Livi range.*

*It is suggested to use articles with control boards integrated.*

## The models

- Product in conformity with European standards.
- Electromechanical automation, 230V ac and 24V dc
- Suitable for gates up to 900 kg.
- Easy to install, thanks to the adjustable fixing plate.
- Integrated limit switches (on 230V ac versions).
- Simple unlocking system by key.
- Mechanical and electronic clutch (on RR models).
- Grease soaked gear motor.
- Silent.



*Simple unlocking system by key.*



*Metal body and highly sturdy components.*

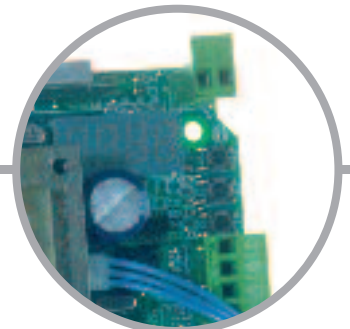

*All control boards included in the RR range can be easily programmed through display and 3 buttons.*

## accessories

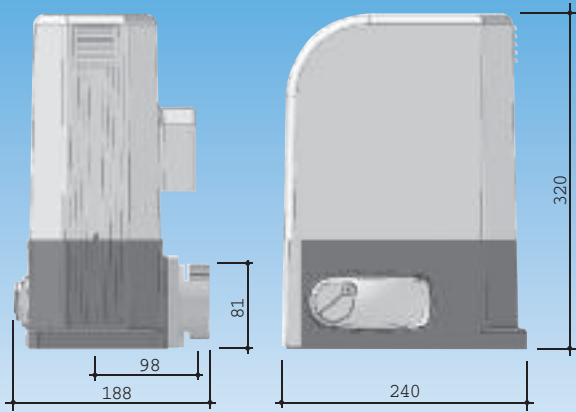

**Art. III**  
NYLON rack.



**Art. II2**  
22x22 GALVANIZED  
rack.



**Art. II3**  
30x12 GALVANIZED rack  
with zinc-plated spacers.



**Art. 460**  
Foundation plate to be  
placed in the concrete.



**Art. 450**  
Unlocking device  
with cable.



**Art. BLIND**  
Safety enclosure to place COD  
external unlocking device handle.

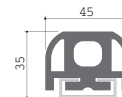

**Art. SOFT**  
Safety rubber profile (complete with  
aluminium base) useful to reduce the  
impact forces. To be used together  
with control boards of range RR

## Technical information

Model	400 6RR - 403E	800 9RR - 803E	804 805RR	5/24RR/F 5/24RRB/F	8/24RR/F 8/24RR/BF
Motor power supply (V)	230 V a.c.	230 V a.c.	230 V a.c.	24 V d.c.	24 V d.c.
Capacity (W)	320	450	350	80	80
Duty cycle	30%	30%	30%	80%	80%
Max thrust (N)	340	490	275	210	260
Operating temperature (°C)	-20°÷40°	-20°÷40°	-20°÷40°	-20°÷40°	-20°÷40°
Speed (m/min)	10	10	10,8	10	8,2
Protection level	IPX4	IPX4	IPX4	IPX4	IPX4
Weight with packing (Kg)	11	12,5	12,5	12	12

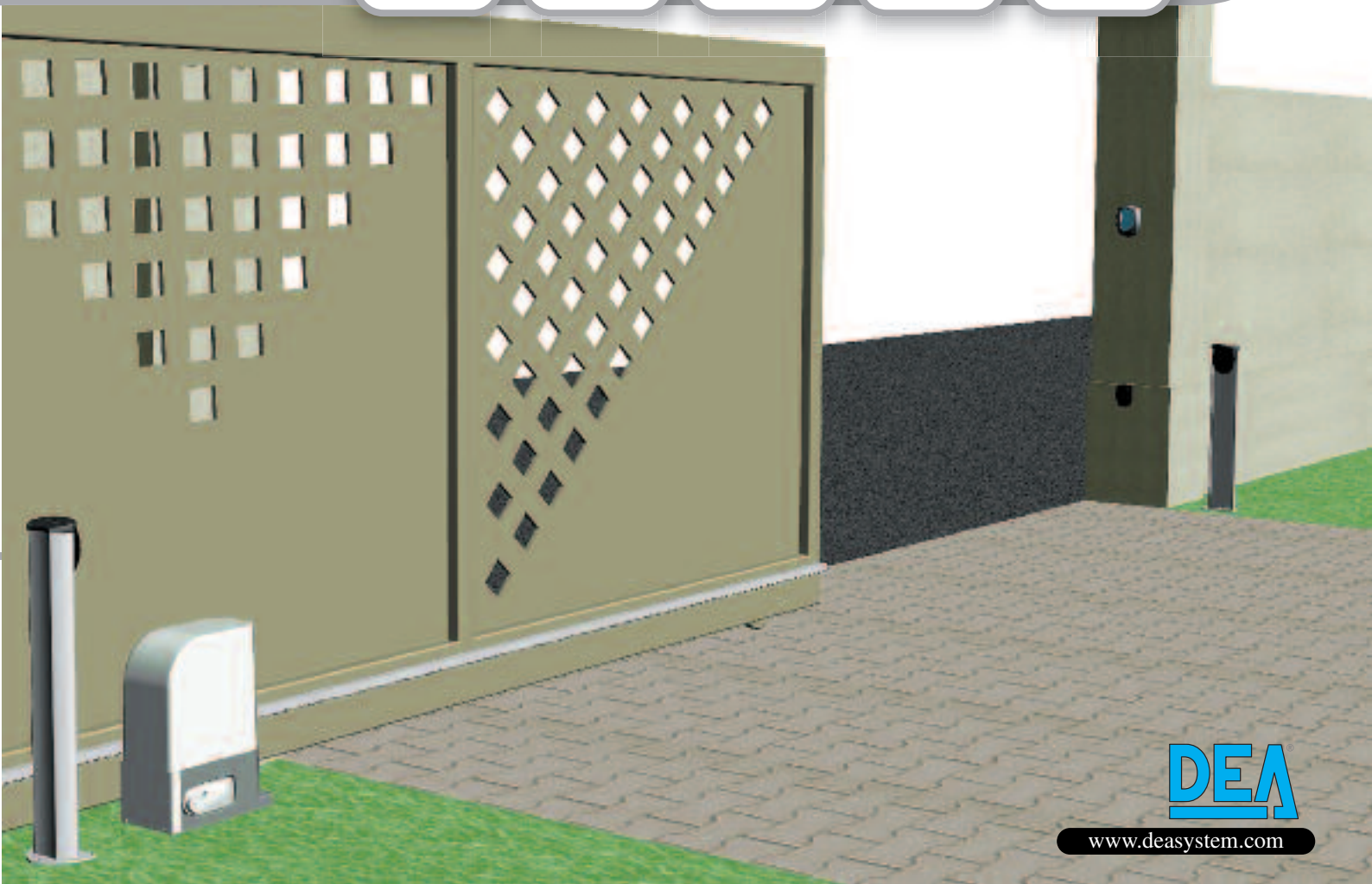



Sectional and garage doors

LIVI 902

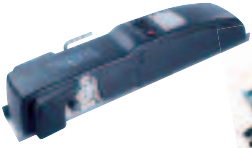

SPAZIO



LIVI 800 C



LATO



LIVI 550PL



Swing gates

LIVI 500

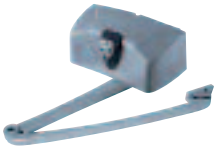

ANGOLO



GHOST 200

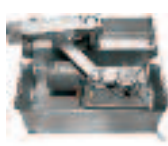

OLI 600



WING 302

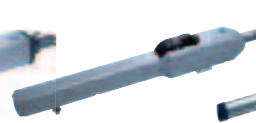

LOOK



Sliding gates

LIVI



GULLIVER



Electromechanical barriers

PASS



STOP



Roller shutter

WILL



the products

the accessories



**Digikey:**  
Safe and reliable,  
available wireless  
and hard-wired.



**Safety beams:**  
reliable and easy  
to install.



**Control boards:**  
230V a.c. e 24V d.c.,  
exact and simple  
programming.



**Flashing light**  
with built-in  
433,92 Mhz  
aerial.



**Radio Devices:**  
Frequency 433,92 Mhz  
Rolling Code  
or cloneable

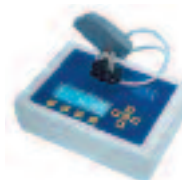

**Programming keyboard** for  
transponder and wireless  
transmission systems; it allows  
you to personalize installations  
with fitter/installation codes.



**DEA SYSTEM S.p.A.**  
Automation for gates, doors and barriers  
Via della Tecnica, 6  
36013 PIOVENE ROCCHETTE (VI) - ITALIA  
Telefono: + 39 0445 550789 - Telefax: + 39 0445 550265  
www.deasystem.com - deasystem@deasystem.com

DEALER STAMP



ISO 9001 certified company  
Certificate n. 50 100 5350